

Setup

Choosing the Materials	2	Inserting Ribbon	11
Label Material	2	Inserting a New Ribbon Roll	11
Thermal Transfer Ribbon	3	Replacing the Ribbon Roll	12
Insertion Diagrams	4	Replacing the Ribbon Roll	12
AP 5.4/AP 5.6 Standard	4	When the Roll is Empty	13
AP 5.4/AP 5.6 with Internal Rewinder	4	End of Material	13
AP 5.4/AP 5.6 Dispenser	5	End of Ribbon	13
Inserting Label Material	6	Settings	14
General Notes	6	Mechanic settings	14
AP 5.4/AP 5.6 Standard	6	Parameter settings	16
AP 5.4/AP 5.6 with Internal Rewinder	9		
AP 5.4/AP 5.6 Dispenser	10		

Choosing the Materials

Label Material

Material specification The AP 5.4/AP 5.6 can process rolls as well as leporello fold (= fold-out or accordion fold material).

▮▮▮▮ The label rolls must be wound with the printable side facing outwards.

For more information on the material specifications, refer to topic section “Technical Data”, chapter [Label Stock](#) on page 9.

Punches/reflex markings

In general, one distinguishes between converted and unconverted material.

- The start of each label is usually marked on converted material. With self-adhesive labels, this can be a gap [1A] between the labels or, with cardboard labels, a small punch [1B] on the edge. If the printer is equipped with the optional reflex sensor, it will be able to detect reflex markings [1C] on the rolls.
- Unconverted material is referred to as “continuous form material” and does not have any label markings. The length of the label is determined through the length setting in the Parameter menu.

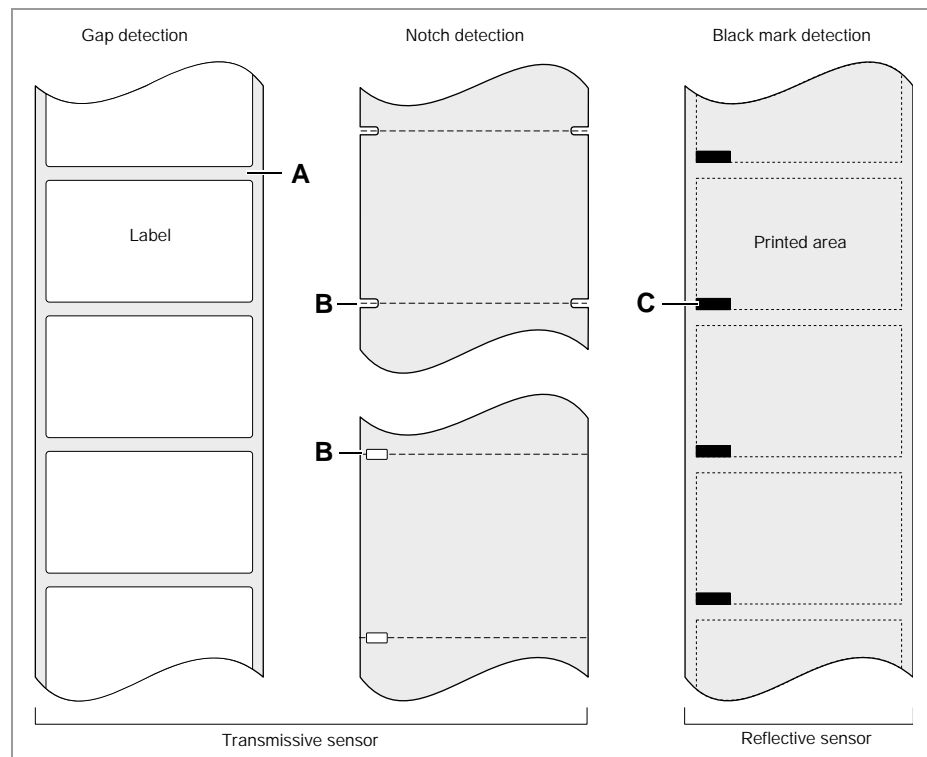

[1] Various types and positions of “start of label” markings.

Quality criteria	<p>Pay attention to the following 3 factors when selecting the quality of label material:</p> <ul style="list-style-type: none">• The abrasive behaviour of the surface structure of the material• The chemical properties of the material that affect how ink is printed• Temperature required for ink transfer
Abrasiveness	<p>If the material is very rough (= strong sanding effect), the printhead will wear down more quickly than with smooth material. This is an important aspect of thermal printing. With thermal transfer printing, this does not pose much of a problem because you can select a ribbon that is wider than the material.</p>
Cleaning the printhead	<p>Similarly, excessively high printhead temperatures can also cause problems. The material and the ribbon require more time to cool down, the printing quality becomes more critical and the printhead will wear down more quickly.</p>

Thermal Transfer Ribbon

We recommend the following for ribbons:

- The ribbon must have a anti-static back coating with low friction.
- The ribbon must be designed for “Flat Head” printheads.
- The ribbons must be able to handle winding speeds of up to 200 mm/s (8 inch/sec).



CAUTION!

Ribbons that do not have these properties can reduce the printer performance and damage the printhead!

Insertion Diagrams

These diagrams display how the material and ribbon moves through the printer under the following conditions:

- Label material must be wound with printed side facing outwards
- Thermal transfer ribbon:
 - Solid line = printed side wound inwards
 - Dashed line = printed side wound outwards

AP 5.4/AP 5.6 Standard

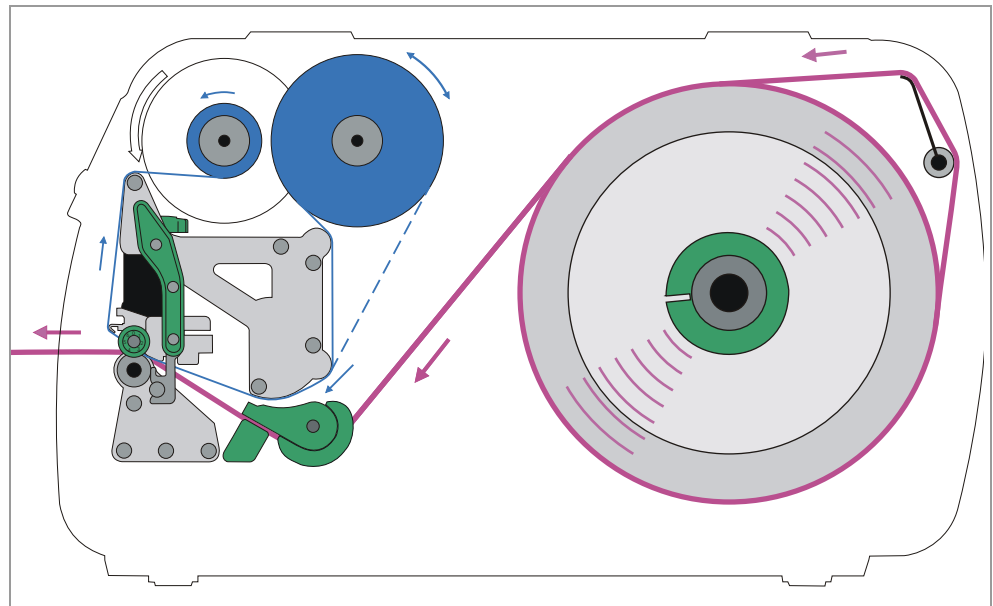

[2] Material and ribbon movement in AP 5.4/AP 5.6.

AP 5.4/AP 5.6 with Internal Rewinder

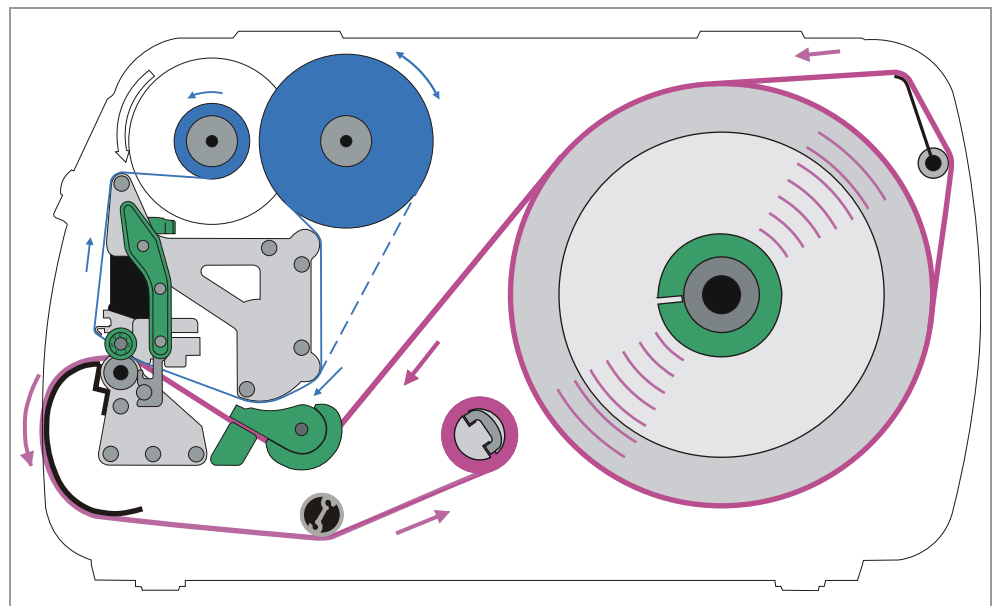

[3] Material and ribbon movement in AP 5.4/AP 5.6 with internal rewriter.

AP 5.4/AP 5.6 Dispenser

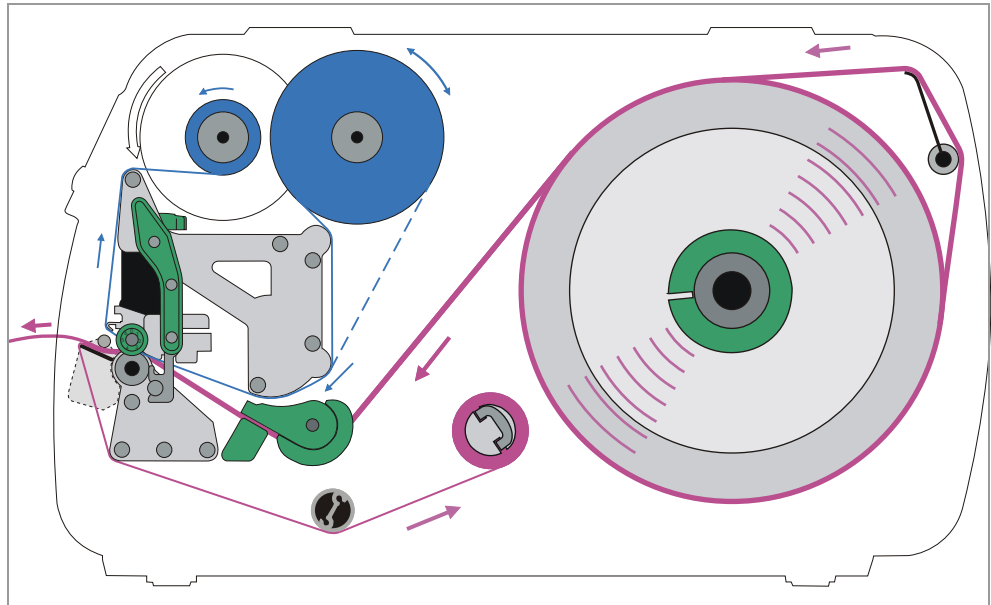

[4] Material and ribbon movement in AP 5.4/AP 5.6 dispenser.

Inserting Label Material

General Notes



WARNING!

Rotating parts can entrap objects and body parts and draw them in!

→ Never wear loose jewellery, long sleeves, long hair or similar when working with the printer.

→ Always close the printer cover before printing.

The printhead can become hot during operation!

→ Be careful whenever touching the printer.

AP 5.4/AP 5.6 Standard

Inserting a label roll

1. Open the front cover.
2. Open the pressure lever [5A] on the print-head.
3. Remove the guiding disk [5B] of the material roller.
4. If necessary, insert two properly fitting adapter disks onto the unwinder.
 - ▣▣▣▣ Choose the spacing between the adapter disks so that the roll of material is supported evenly.
5. Push the roll of material onto the unwinder. Re-attach the guiding disk and push it up to the roll of material.
 - ▣▣▣▣ The roll of material must rotate counter-clockwise while unwinding!

Continued on next page

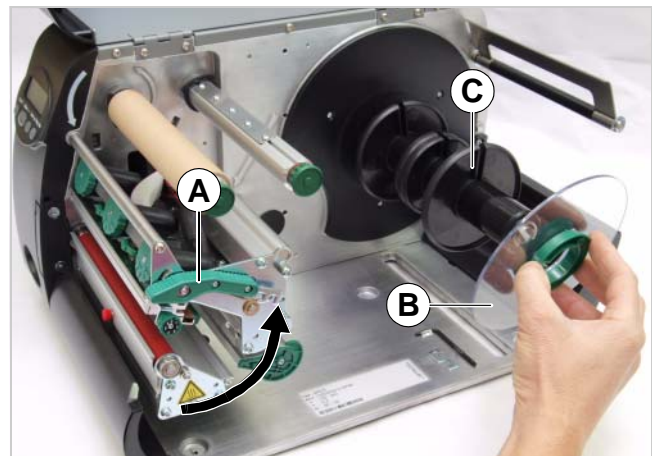

[5] Preparing the material unwinder on AP 5.6.

6. Insert the material as shown [6].

▣▣▣▣ Also make sure to push the material around the material strain-relief [6A]!

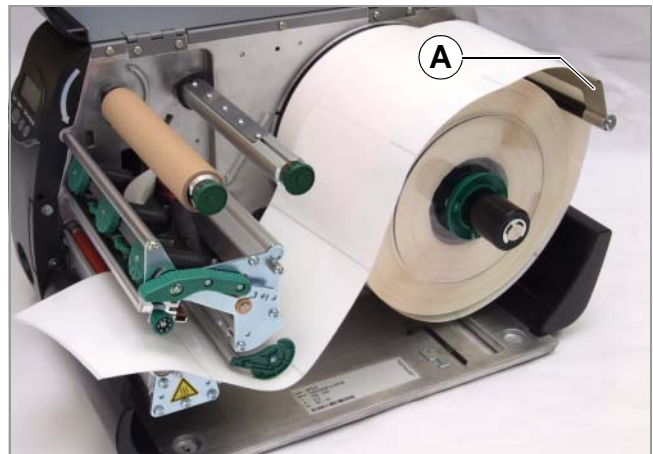

[6] Inserting the label material.

7. Push the material guiding [7A] up to the edge of the material without clamping the material.

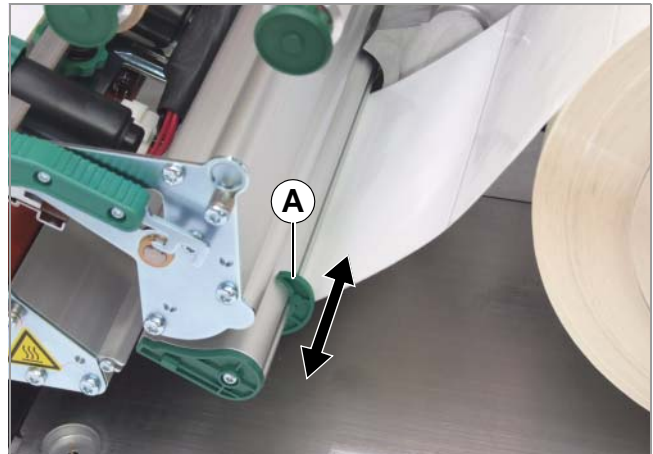

[7] Adjusting the material guide (A).

8. Push the sensor arm using the handle [8A] until the indicator [8B] is above the punches on the material.

▣▣▣▣ The optional *reflex light sensor* is located 6 mm to the right of the indicator!

9. *Direct thermal* printing: Close the pressure lever. *Thermal transfer* printing: Insert ribbon, see chapter [Inserting Ribbon](#) on page 11.

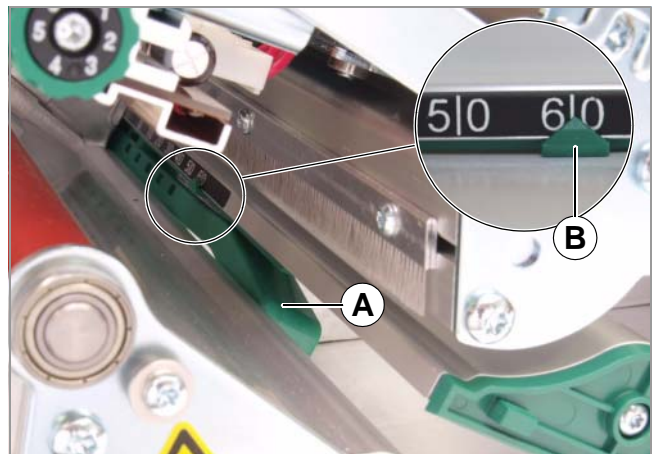

[8] Adjusting the label sensor (figure w/o material).

Inserting Leporello Fold

Alternatively to the roller material, you can also use leporello fold (accordion fold):

1. Open the front cover.
2. Open the pressure lever on the printhead.
3. Place the leporello fold [9A] behind the printer.
4. Push the material over the material unwinder. Push the guiding disk up to the edge of the material without clamping the material.
5. Continue as described in steps 6 to 8 in [Inserting a label roll](#) on page 6.

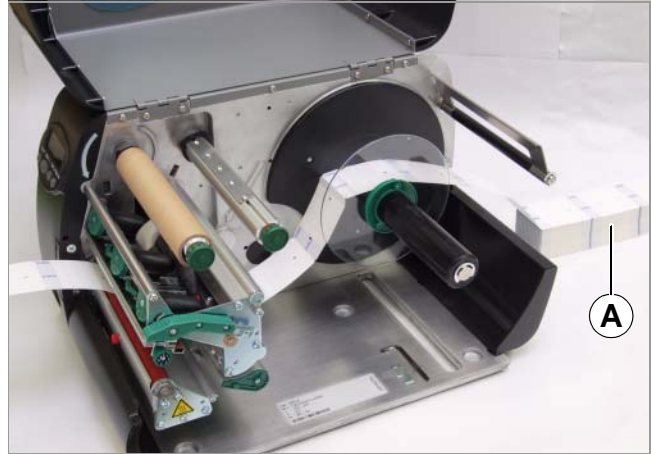

[9] Inserting the leporello fold (A).

AP 5.4/AP 5.6 with Internal Rewinder

1. Insert the label material, see [Inserting a label roll](#) on page 6.
2. As shown, move the end of the label strip towards the rewriter [10A] and fasten it to the clasp [10B].
 - ▮▮▮▮▮ The short side of the stay bolt fits into the groove [12A].
3. Choose the direction of rotation for the rewriter (printout facing inwards or outwards): Choose the `REWINDER PARA > Rewind direction` parameter.

After switching on the printer, the rewriter slowly rotates in the configured direction until the material ribbon becomes taut.

The following error message might appear until the material ribbon is taut.

Status	5004
Rewriter mat. tear	

→ If this happens, press the Online key (repeatedly if necessary) to acknowledge the message.

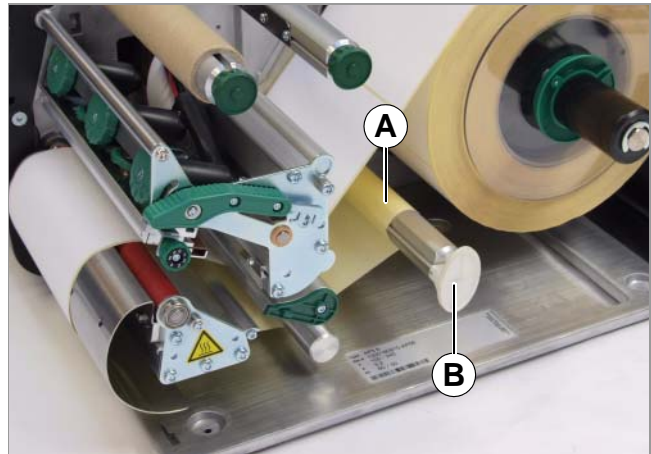

[10] Material path through an AP 5.6 with internal rewriter.

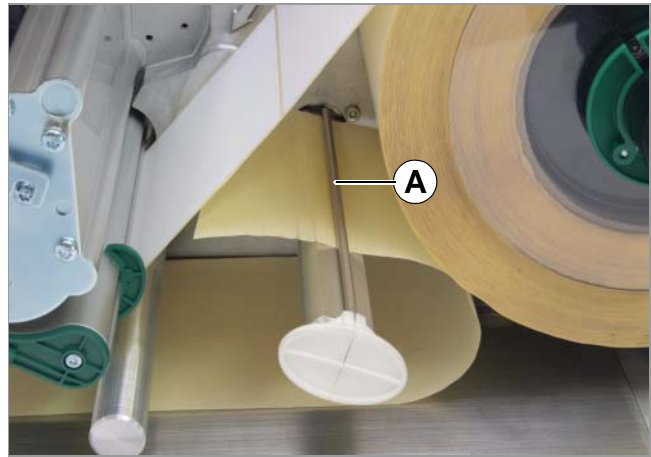

[11] Fix the label strip on the rewriter.

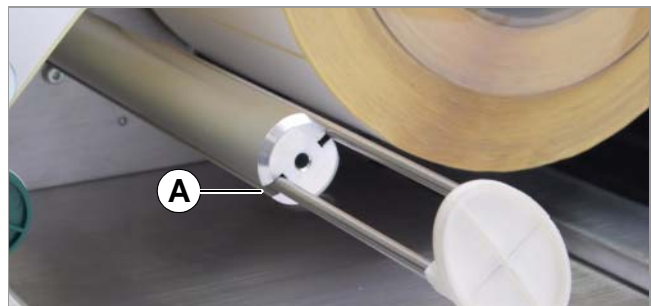

[12] Insert the clasp with the short side into the groove (A).

AP 5.4/AP 5.6 Dispenser

1. Inserting the label material, see [Inserting a label roll](#) on page 6.
2. Remove the release paper from the labels to approx. 30 cm away from the end of the label strip [14].
3. Press the red button [13A] on the dispensing edge to unlock the dispensing roll. Remove the dispensing roll [13B]

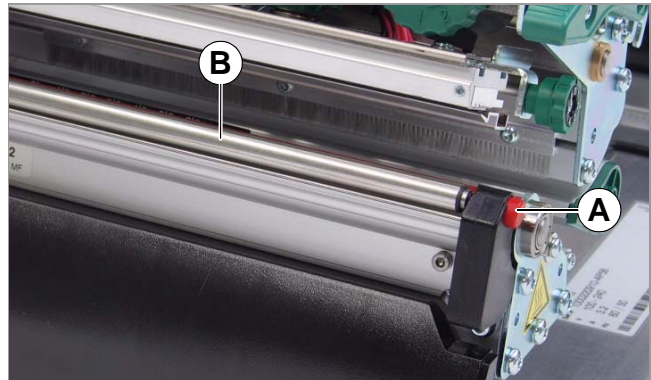

[13] Dispenser roll (B) above dispenser edge.

4. As shown, move the backing paper towards the rewinder [14A].

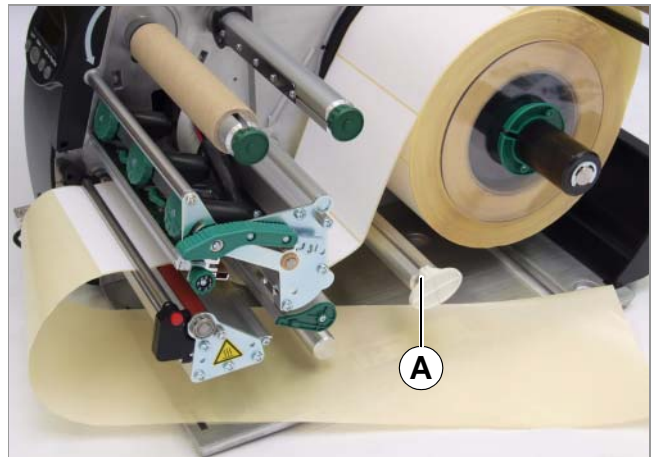

[14] Move the covering paper towards the rewinder (A).

5. Fasten the end of the backing paper strip to the clasp [15A].

▮▮▮▮▶ The short side of the clasp fits into the groove [16A].

6. Manually rotate the rewinder in a counter-clockwise direction until the backing paper is taut.

7. Reconnect the dispensing roll.

After switching on the printer, the rewinder slowly rotates until the material ribbon becomes taut.

The following error message might appear until the release paper is taut.

Status	5004
Rewinder mat. tear	

➔ Press the Online key (repeatedly if necessary) to acknowledge the message.

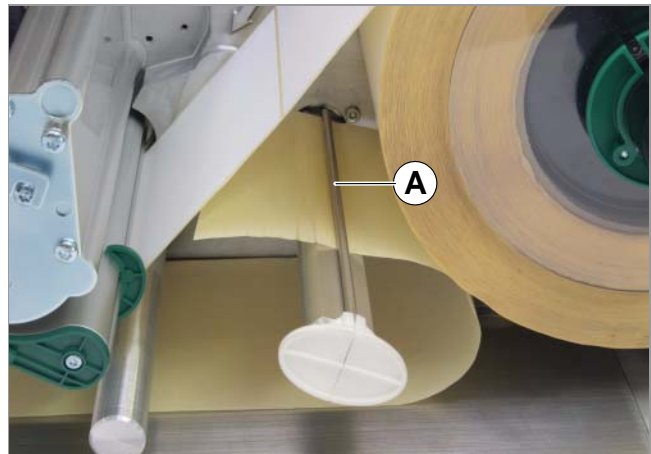

[15] Fasten the covering paper to the rewinder.

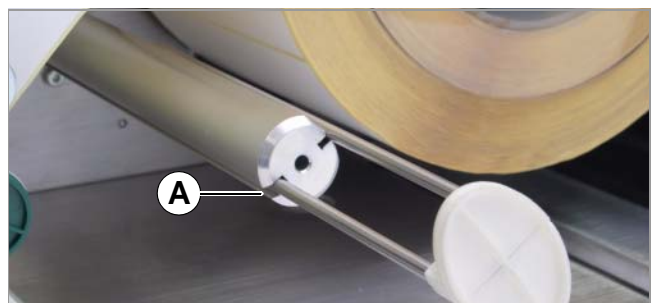

[16] Insert the clasp with the short side into the groove (A).

Inserting Ribbon



WARNING!

Rotating parts can entrap objects and body parts and draw them in!

→ Never wear loose jewellery, long sleeves, long hair or similar when working with the printer.

→ Always close the printer cover before printing.

The printhead can become hot during operation!

→ Be careful whenever touching the printer.



CAUTION!

Poor printing quality.

→ The thermal transfer ribbon must overlap the label width 2 mm on each side (ribbon width = label width + 2 mm)^a.

a) Exception: The label material width exceeds the printhead width. In this case, ribbon must not be wider as the printhead (= max. ribbon width).

▮▮▮▮ Ribbon only has to be inserted for thermal transfer printing.

Inserting a New Ribbon Roll

1. Open the front cover.
2. Open the pressure lever [17A] on the printhead.
3. Push the ribbon roll [17B] onto the unwinding mandrel until it stops. Push the empty ribbon sleeve onto the rewinding mandrel [17C].

▮▮▮▮ The ribbon rotates in a counter-clockwise direction with the coloured side facing inwards (see fig.)!

4. As shown, insert the ribbon into the printer [17] [18]. Fasten the end of the ribbon with adhesive tape to the empty ribbon sleeve.
5. Rotate the rewinding mandrel a few turns in a counter-clockwise direction until the ribbon is free of folds.

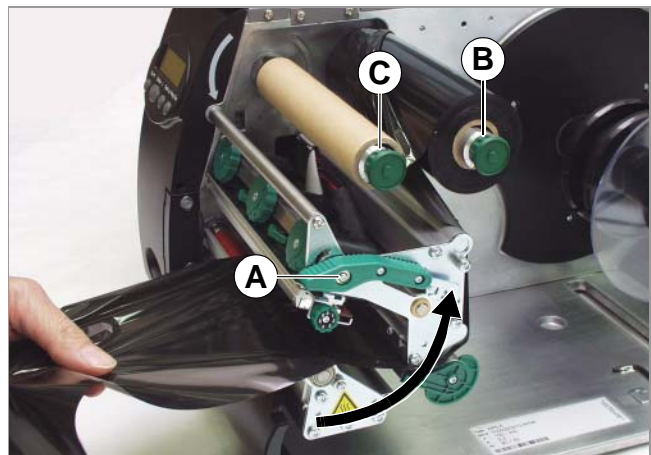

[17] Insert the ribbon.

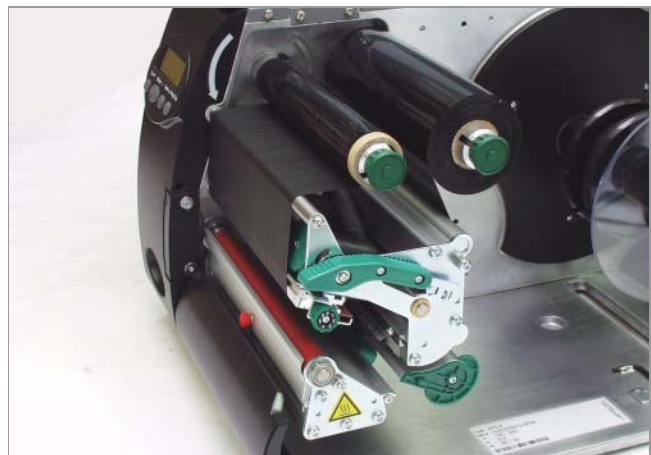

[18] Fasten the ribbon and tighten the ribbon.

Replacing the Ribbon Roll

1. Open the pressure lever on the printhead.
2. Remove the wound roll of ribbon from the rewinding mandrel.
3. Remove the empty core of ribbon from the unwinding mandrel and place this onto the rewinding mandrel.
4. Clean the printhead.
See topic section „Maintenance and cleaning“, chapter [Cleaning the Printhead](#) on page 6.
5. Insert a new roll of ribbon as described above.

Replacing the Ribbon Roll

To switch between *different types of ribbons*, there is no need to cut off the ribbon each time and then insert it and fasten it to the ribbon re-winder.

It's easier as follows:

1. Open the pressure lever [19].
2. Remove both rolls of ribbon from the mandrels. Pull away the ribbon sideways from the printhead [20].
 ■■■► Store your frequently used ribbons as pairs of rolls [21].

You can insert another pair of rolls as follows:

1. Push the ribbon between the rolls sideways below the printhead [20].
2. Push the ribbon rolls onto the mandrels and tighten the ribbon [19].

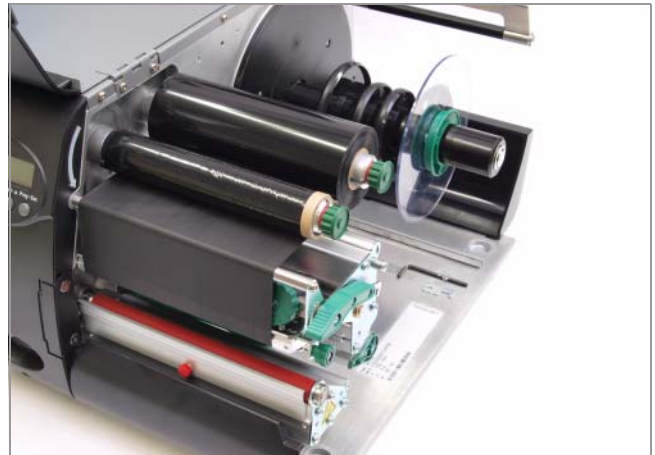

[19] AP 5.4 with inserted ribbon, pressure lever is open.



[20] Remove both ribbon rolls.

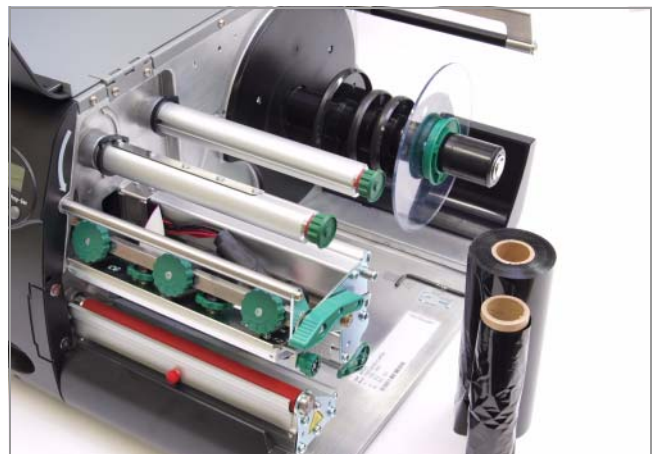

[21] Store the ribbon rolls in pairs.

When the Roll is Empty

End of Material

After the end of the material roll passes by the punch sensor, the following status message appears:

Status	5002
Material end	

→ Open the pressure lever and pull the end of the material forwards out of the printer.

End of Ribbon

Once the end of the ribbon has been wound away and the unwinding mandrel no longer rotates, the following message will appear:

Status	5008
Ribbon end	

→ Proceed as described under [Inserting a New Ribbon Roll](#) on page 11.

▮▮▮▮ End-of-ribbon detection can be shut off when required, e.g. for direct thermal printing:

→ To do this, set `SYSTEM PARAMETERS > Foil mode` to “Thermal printing”.

For more detailed information on how to set the parameters, see [Info Printouts and Parameters](#).

Settings

Mechanic settings

Ribbon brake (AP 5.6)

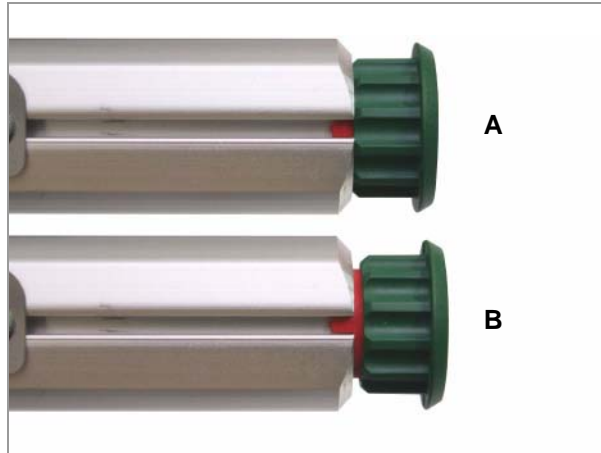

[5] Adjusting knob at the ribbon mandrels

- A Setting for low braking torque
- B Setting for high braking torque

The braking torque of the AP 5.6 ribbon mandrels can be set in two strengths.

- High braking torque = red ring is visible [5B]
- Low braking torque = red ring is *not* visible [5A]

Changing the braking torque:

➔ Pull at the green adjusting knob and turn it $\frac{1}{4}$ rotation, until it snaps in.

- Increasing the braking torque: turn *clockwise*
- Decreasing the braking torque: turn *anti-clockwise*

⚠ Always keep the unwinding mandrel set to „low braking torque“. Exception: printing with long backward movement stretch (PRINT PARAMETERS > Cut mode = „Real 1:1 mode“ or DISPENSER PARA > Dispense Mode = „Real 1:1 mode“)

Ribbon width	Setting rewinding mandrel
50-90 mm	low braking torque [5A]
90-110 mm	both settings possible
110-172 mm	high braking torque [5B]

[Tab. 1] Typical values for setting the ribbon brake.

Printhead pressure

In some cases, the blackness of the printout is not sufficient with the standard setting, e. g. when printing on cardboard material. If this happens, the blackness can be increased by the following measures:

- Increasing the print contrast (SYSTEM PARAMETER > Print contrast or, in online mode, pressing the Prog button)
- Increase the printhead (contact) pressure (set adjusting knobs [6A] to a higher value; turn each knob until the desired number is placed opposite of the edge [6B])

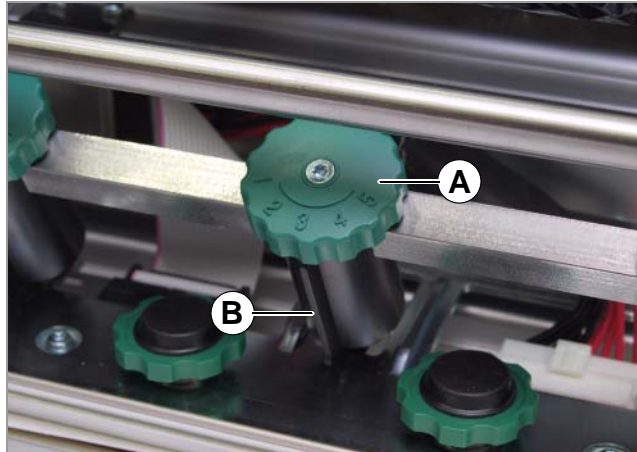

[6] Adjusting knob (A) for the printhead contact pressure.

Printhead Support

When printing narrow labels, the printhead can come into direct contact with the print roller in areas where no material is present. This can cause preliminary wear and tear on the printhead and can lead to varying printing intensities between the two label edges.

▮▮▮▮ When using narrow labels, activate the printhead support! *Narrow = material width < printhead width.*

The printhead support setting is indicated by the position of the thumb wheel [5A]. For wide labels, we recommend the “0” setting.

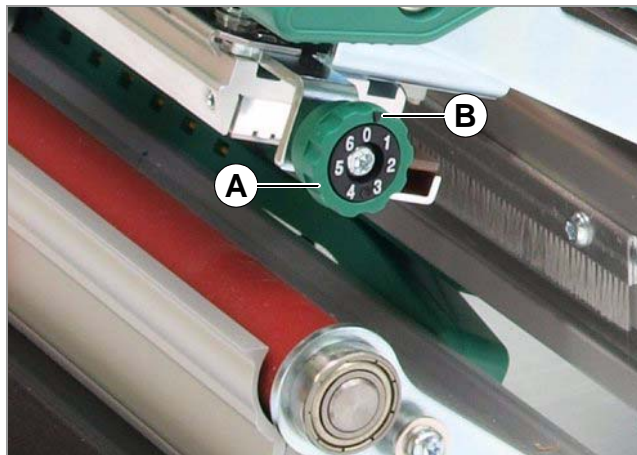

[7] Thumb wheel (A) for printhead support.

1. For narrow labels, turn the thumb wheel clockwise until the marking [5B] points to “1”. The printhead is lifted on the outside.

2. Make a test printout and check the evenness of the printed results. If the printing intensity is not even, turn the thumb wheel even further.
3. Repeat steps 1 to 3 until the print intensity is even across the entire label width.

Parameter settings

Material Parameters Using the following three parameters, you can enter the properties of the label material to be printed on the printer:

Parameter	Function
PRINT PARAMETERS > Material type	Sets the material type (punched or continuous)
PRINT PARAMETERS > Material length	Sets the label length (start of label to end of label)
PRINT PARAMETERS > Material width	Sets the material width
SYSTEM PARAMETER > Light sens. type	Sets the sensor type (reflex or transmission) according to material type (reflex markings or punches)

For more information on how to set the parameters, see “Info Printouts and Parameters”, section [Operating the Parameter Menu](#).

Setting the label length automatically

After pressing the button, the printer transports the label material forwards until two start-of-label markings have passed by the label sensor. The label length thus determined will be displayed and applied to PRINT PARAMETERS > Material length. Furthermore, PRINT PARAMETERS > Material type is set to “Punched”.

Display of the measured label length:

```
OFFLINE x JOBS
      198.5 mm
```

► This function measures the label length without punches, i.e., from the start of the label to the end of the label. For label material with very large punches, we recommend measuring the label length manually and then entering this value (label length + punch).

Ribbon Parameters Using this parameter, you can configure whether to use direct thermal printing (without ribbon) or thermal transfer printing (with ribbon).

Parameter	Function
SYSTEM PARAMETER > Foil mode	Set to thermal transfer or direct thermal printing.

Parameters for Dispenser Mode ► Setting only for AP 5.4/AP 5.6 “basic” dispenser and for AP 5.4/AP 5.6 “peripheral” dispenser.

Parameter	Function
SYSTEM PARAMETER > Periph. device	Set to “Dispenser”

Parameters for Rewinding Mode

▶ Setting only for AP 5.4/AP 5.6 “basic” dispenser and for AP 5.4/AP 5.6 “peripheral” dispenser.

Parameter	Function
SYSTEM PARAMETER > Periph. device	Set to “Intern rewinder”.
REWINDER PARA > Rewind. direction	Select the direction of rotation (print-out facing inwards or outwards).

Maintenance and Cleaning

General Notice	2	Printhead	5
Maintenance by Qualified Personnel	2	Important Handling Notes	5
Safety	2	Cleaning the Printhead	6
Troubleshooting	2	Changing the Printhead	8
Ordering Spare Parts	3	Print Roller	9
Note on Cleaning	3	Cleaning the Print Roller	9
Cleaning Agents	4	Changing the Print Roller	10
		Punch Sensor	11

General Notice

Maintenance by Qualified Personnel

Regular technical maintenance is required to ensure that the device is always in operating order.

Qualifications

Maintenance work should only be carried out by qualified personnel. The safety, reliability and longevity of the device depend on correct maintenance.

► Persons causing damage as a result of unqualified maintenance, repair and care are liable for these costs.

Manufacturer Service

For reliable maintenance, servicing, diagnosis and troubleshooting, please contact your supplier, nearest dealer or another service supplier authorized by the manufacturer.

Safety



WARNING!

Maintenance and cleaning may result in hazardous situations. Accidents can occur by mechanical or electrical means if safety instructions are not observed!

→ Turn off the device and disconnect the power cable prior to cleaning or maintenance work!

→ On no account should liquid be allowed to enter the device!

→ Do not use any of kind of spray directly on the printer! Moisten a cloth with a cleaning agent to clean the device!

→ Repairs to the printer may only be carried out by a trained service technician!

Troubleshooting

Status

If device malfunctions occur, analyze the device messages first. Please read the relevant chapter contained in this documentation.

Calling for Service

If you are not authorized to carry out a diagnosis and repair of problems, please call your technician or authorized service supplier. The service personnel have the required information and replacement parts to correctly carry out the repairs.

Ordering Spare Parts



CAUTION! - Using parts that do not meet the manufacturer's high standards may damage the machine.

→ Only use original spare parts supplied by the manufacturer.

The following information is required when ordering spare parts:

Order Specifications

- Model
- Device serial number
- Optional device configuration
- Description and part number of the spare part
- Number of parts required

Note on Cleaning

Frequency of Care

Frequent maintenance and cleaning is required to ensure that the device operates safely and provides a high level of performance. The frequency with which maintenance checks are required depends on operating and environmental conditions, the length of operation daily, and the print media used.

▣ In particular, the printhead and feed roller need to be checked regularly for paper, adhesives and ink residues.

Cleaning Agents



CAUTION!

The printer can be damaged by aggressive cleaning agents.

- Do not use any cleaning agent that could damage or destroy the resin surface, labelling, display, nameplates, electrical components, etc.
- Do not use any cleaning agents that are abrasive or solvent to plastics. Avoid acid or alkaline solutions.



[1] Printhead cleaning pen (A) and roller cleaner (B).

Dirty component	Cleaning agent	Order number
Printhead	Printhead Cleaning pen [1A]	95327
Print roller and other rubber rollers	Roller cleaner [1B]	98925
Metal deflection axis or -guide tube	Cleaning fuel Label remover	90073
External parts	Common neutral cleaning liquid	

[Tab. 1] Recommended cleaning agents.

Printhead

Important Handling Notes

**CAUTION!**

Printhead can be damaged.

- Protect the printhead [1] from electrostatic discharges when performing maintenance work or cleaning.^a
- Do not touch the thermal edge [1C].
- Do not use sharp or hard objects to clean the printhead.

- a) If you do not have any professional ESD protection equipment (ESD wristband, ESD shoes, ...): place one hand on an earthed object near to you (e.g. a radiator) before touching the device, to discharge any static charge your body may be carrying.

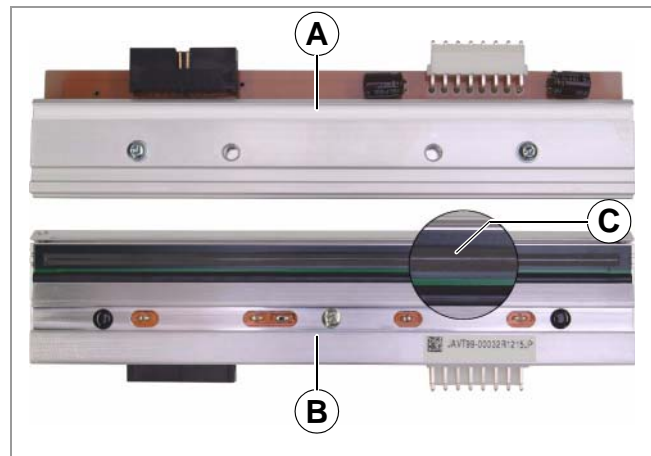

[1] Printhead viewed at from the top (A) and bottom (B).

Cleaning the Printhead



WARNING!

Risk of burning injuries from a hot printhead.

→ Ensure that the printhead has cooled down before cleaning it.

Impurities such as lint and color particles from the thermotransfer foil may collect on the printhead during printing. This can lead to a noticeable detrimental effect on the printed image, shown by:

- Differing contrast on the labels
- Light stripes in the printing direction

▮ Clean printhead regularly to ensure optimal print head condition.

Cleaning intervals

- Thermal transfer printing: after each used up ribbon roll
- Direct thermal printing: after each used up label roll

Preparation

1. Switch off the printer.
2. Open the printhead pressure lever. The printhead folds upwards.
3. Remove material and foil from the printer.

Cleaning with a cleaning pen

→ Applying light pressure, go over the thermal edge [2B] a few times with the cleaning pen [2A].

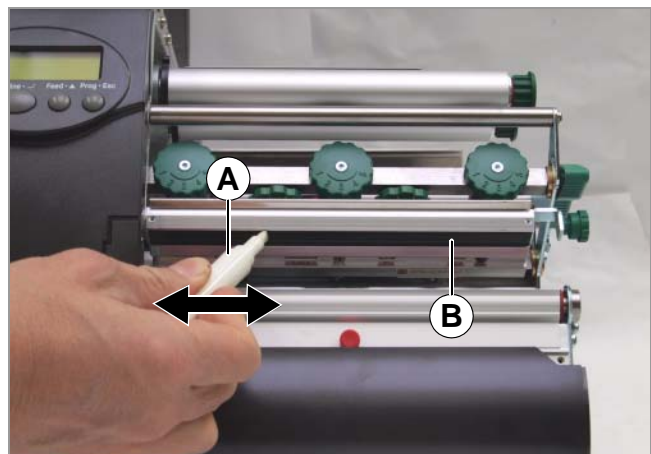

[2] Cleaning the thermal edge with a cleaning pen (A).

Cleaning with cleaning paper

1. Cut a strip of cleaning paper matching the printhead width.
2. Insert the cleaning paper (2) into the printer with the rough side facing upwards (Fig. 2).
3. Close the pressure lever.
4. Move the cleaning paper back and forth repeatedly (Fig. 3).

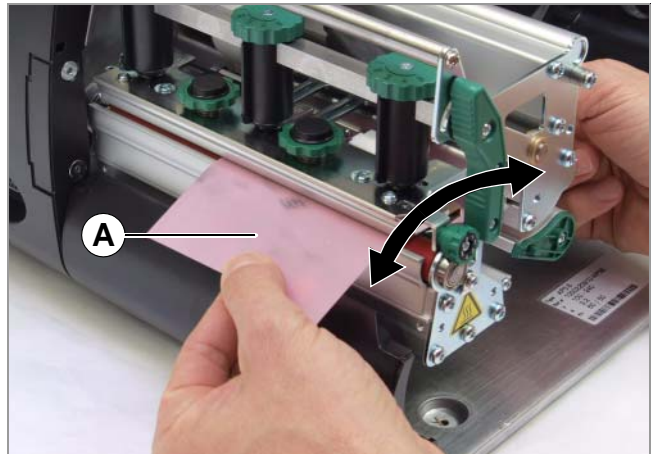

[3] Cleaning the thermal edge with cleaning paper (A).

Cleaning with pure alcohol



CAUTION!

Risk of fire due to a flammable liquid.

- Observe the safety instructions on the alcohol bottle.
- Don't smoke.

⚠️ Only use alcohol-based solvents¹ when the other two cleaning agents are not available!

→ Moisten a lint-free cloth with alcohol; wipe the thermal edge with the cloth.

→ Allow printhead to dry for several minutes.

1) For example ethanol or isopropyl alcohol.

Changing the Printhead



WARNING!

Risk of burning injuries from a hot printhead.

→ Ensure that the printhead has cooled down before cleaning it.



CAUTION!

Printhead misalignment.

→ Don't loosen the screws [7C] fixing the printhead on the bracket.

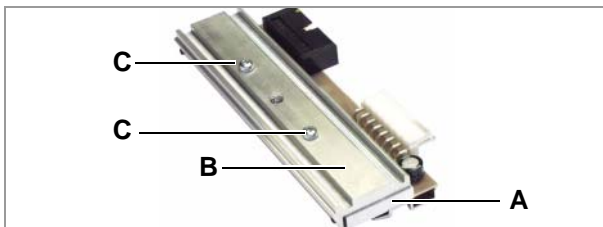

[7] Printhead (A) and bracket (B) were adjusted exactly by means of special positioning tools.

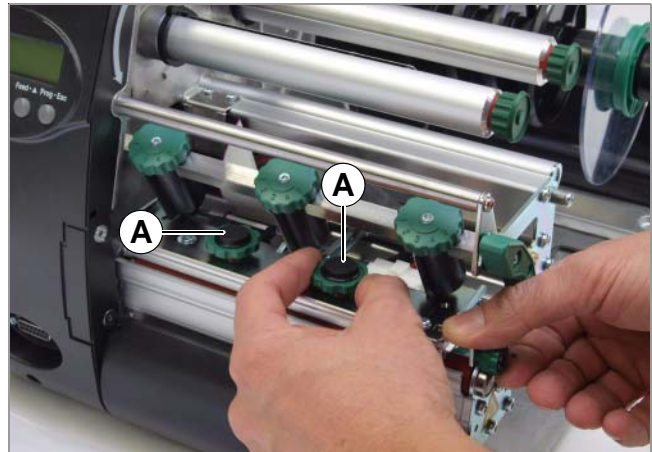

[4] Turning out the thumb screws (A) .

Dismantling the printhead:

1. Switch off the printer and disconnect from the power.
2. Remove material and foil from the printer.
3. Close the pressure lever (1).
4. Remove the knurled screws (2) (Fig. 1).
5. Open the pressure lever.

The printhead is released from the fastener and remains on the print roller (Fig. 2).

6. Remove both printhead cables from the printhead (Fig. 3).
7. Remove the printhead.

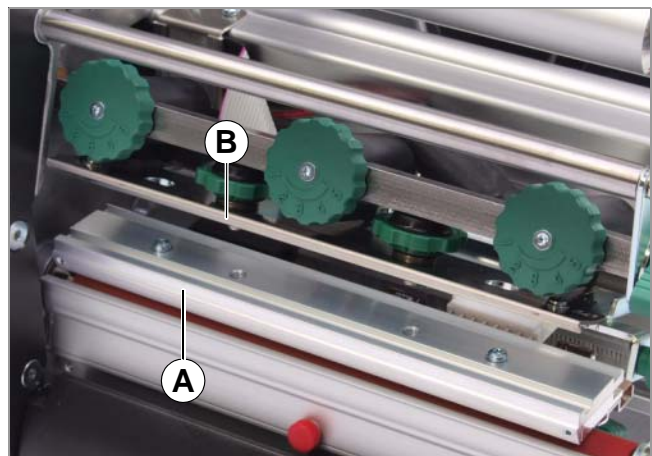

[5] Printhead (A) removed from the holder (B).

Fitting the printhead:

1. Note the resistance of the new printhead. You can read this on a sticker directly on the printhead!
2. Affix the printhead cable.
3. Press the printhead against the fastener from below and tighten the knurled screws.
4. Call up the parameter `SYSTEM PARAMETERS > Head resistance` and enter the printhead resistance you noted earlier.

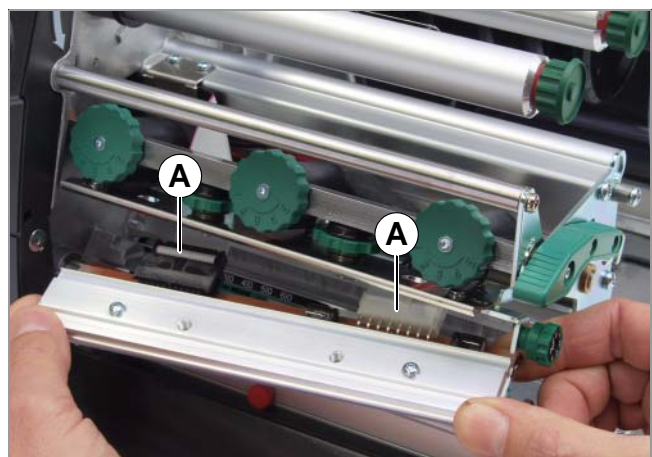

[6] Pulling off the printhead cables (A).

Print Roller

Cleaning the Print Roller



WARNING!

Risk of burning injuries from a hot printhead.

→ Ensure that the printhead has cooled down before cleaning it.

Contamination on the print roller can degrade the quality of the print and the transport of the material.

1. Switch off the printer and disconnect from the power
2. Remove material and foil from the printer.
 - ▮▮▮ You can access the print roller more easily if you remove the tear-off edge [8A] beforehand.
3. To do this, unfasten the screw [8B] in the middle of the tear-off edge. Remove the tear-off edge [9].
4. Moisten a lint-free cloth with roller cleaner and wipe the printer roller [10]. Gradually rotate the roller until it is completely clean.
5. Refit the tear-off edge.

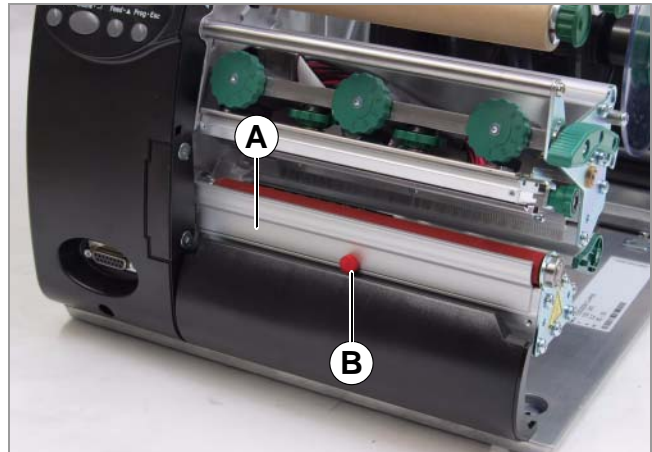

[8] Abreißkante (A) am AP 5.6.

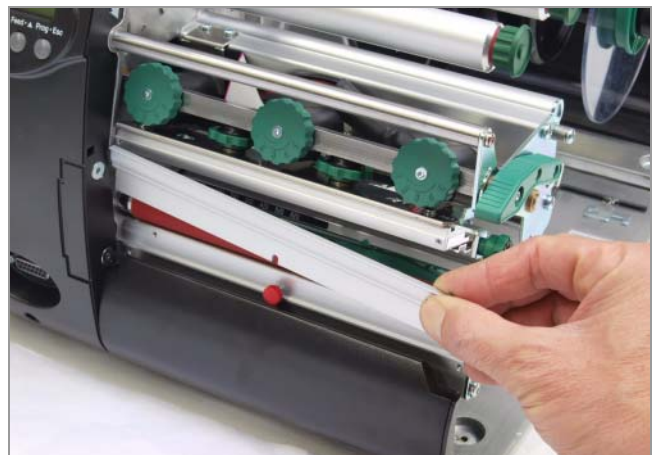

[9] Abreißkante abnehmen.

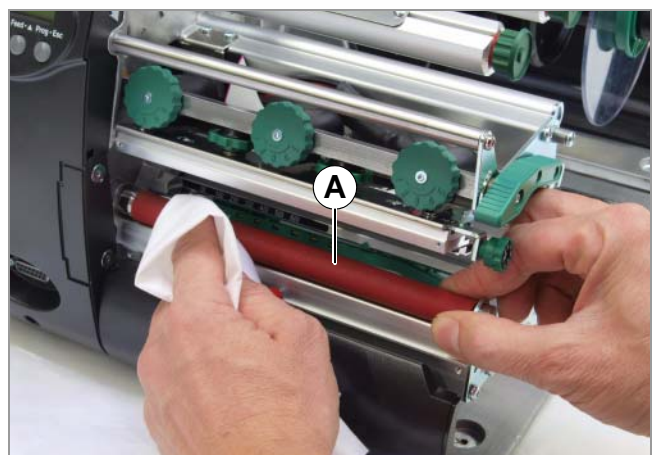

[10] Druckwalze abwischen.

Changing the Print Roller



WARNING!

Risk of burning injuries from a hot printhead.

→ Ensure that the printhead has cooled down before cleaning it.

Tool

2,5 mm hex screwdriver (comes with the printer).

Disassembly:

1. Switch off the printer and disconnect from the power.
2. Remove material and foil from the printer.
3. Unfasten the screw [11B] in the middle of the tear-off edge [11A]. Remove the tear-off edge.
4. Release the set screw [11C].
5. Remove the print roller sideways [12].

Fitting:

1. Push the print roller through the external bearing plate.
The printer roller axle is flattened on the end.
2. Place the axle in the socket [12B] and gently rotate until the flat part [12C] of the axle is under the set screw.
3. Press the print roller firmly into the socket.
▶▶▶ Ball bearing [13B] and bearing plate [13A] must flush on the inner side!
4. Fasten the set screw.

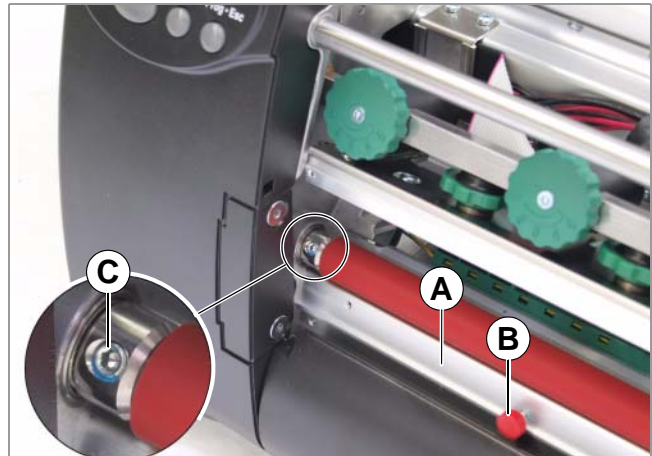

[11] Print roller at an AP 5.6.

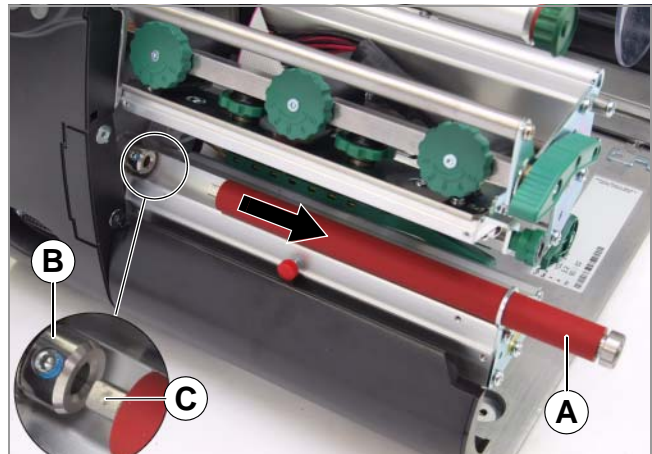

[12] Pull out the print roller (A).

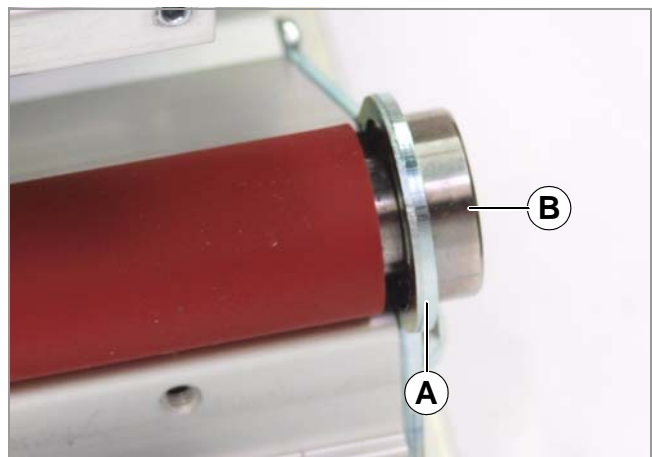

[13] The ball bearing (B) and bearing plate (A) must flush at the inner side.

Punch Sensor

During printing the punch sensor can become contaminated with lint. Large amounts of dirt can lead to problems with perforation recognition.

To free the punch sensor from dust and abraded particles:

1. Remove the cover [14A] gently and swivel downwards.
2. Remove the sensor arm [15A].
3. Clean the opening [15B] with compressed air.



CAUTION!

Label sensor can be damaged.

→ Do *not* use sharp or hard objects or solvents to clean the label sensors.

▮▮▮ The light transmission sensor is situated in the upper and the lower part of the sensor arm on a level with the indicator [15C]. The reflex sensor is situated about 5 mm further out in the lower part.

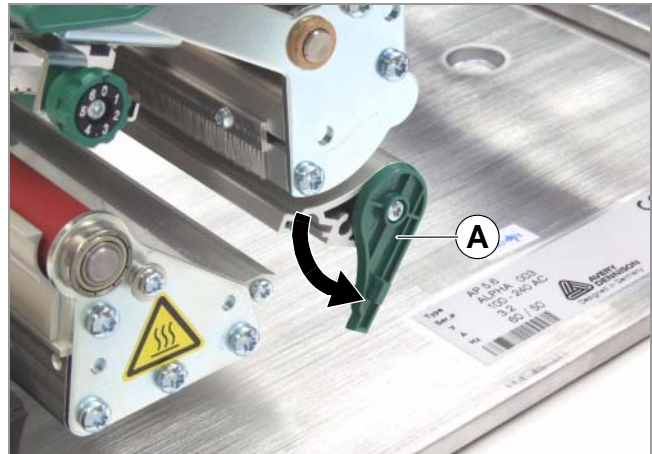

[14] Open the cover (A).

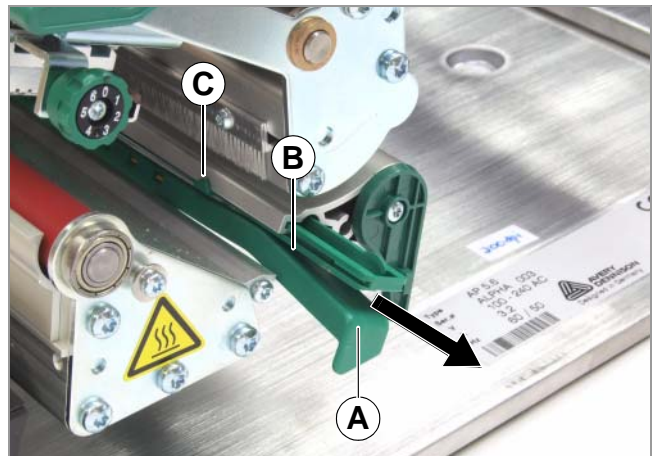

[15] Pull out the label sensor fork (A)..

Technical Data

Application, Device Types	2	Connections, device data	10
Application	2	Interfaces	10
Device types	2	Electronic Configuration	11
Options	3	Specifications only for	
Technical Specifications	4	AP 5.4/5.6 dispenser	11
Dimensions	4	Environmental Conditions	11
Performance Data	5	Test Marks, certificates	12
Label Stock	9		
Thermotransfer Ribbon	10		

Application, Device Types

Application

- Monotone printing of label stock for thermal and thermotransfer processes
- Printing on different materials, e.g. cardboard or self-adhesive labels, which are suitable for thermal- or thermotransfer printing
- Processing roll and fan-folded material
- Resolution: 8.0 or 11.8 Dot/mm (203 or 300 dpi)
- Print speed up to 200 mm/sec (8"/s)
- Print width:
 - AP 5.6: up to 168 mm
 - AP 5.4: up to 105 mm
- Interfaces: RS -232, USB,, Ethernet, and connection for foot switch

Device types

AP 5.4 and AP 5.6 are available in 4 versions:

Basic

AP 5.4/5.6 equipped with serial, USB and Ethernet interface and SD-card slot. Possible upgrade to „peripheral“ version.

The following options can be integrated:

- Reflex sensor (top and/or bottom)
- I/O board (signal interface and additional serial interface)

Peripheral

Like the AP 5.4/5.6 basic, but with capability to add the following options:

- External rewinder (for AP 5.4 only)
- Cutter

„Basic dispenser“ or „peripheral dispenser“

AP 5.4/5.6 with additional built-in internal rewinder. In connection with an optional dispensing edge, this printer can also be used as a dispenser. If the dispensing edge is replaced by a deflection plate, the printed labels are not dispensed, but rewound together with the backing paper.

Options

Internal Options

...should be factory-fitted or installed by a service engineer:

- *Reflex Sensor Kit*: Light barrier fitting that apart from the transmission sensor, also contains a reflex sensor.
- *Label sensor for short labels*. Recommended for label length < 30 mm.
- *Internal rewinder kit*: To retrofit the internal rewinder; contains the rewinder as well as the driver board and material guide
- *I/O board*: RS- 422/485 interface, signal interface

External Options

...do not require any special alterations to the printer:

- *Cutter* (required printer: AP 5.4/5.6 peripheral)
- AP 5.4 only: (*External*) *rewinder* for material rolls with 38 mm (1.5"), 75 mm (3") or 100 mm (4") cores (required printer: AP 5.4 peripheral)
- *Keyboard* for standalone operation
- *Foot switch* for foot-operated label dispensing
- *Dispensing edge* (required printer: AP 5.4/5.6 „basic“ or „peripheral“ with internal rewinder)

Technical Specifications

Dimensions

Measures

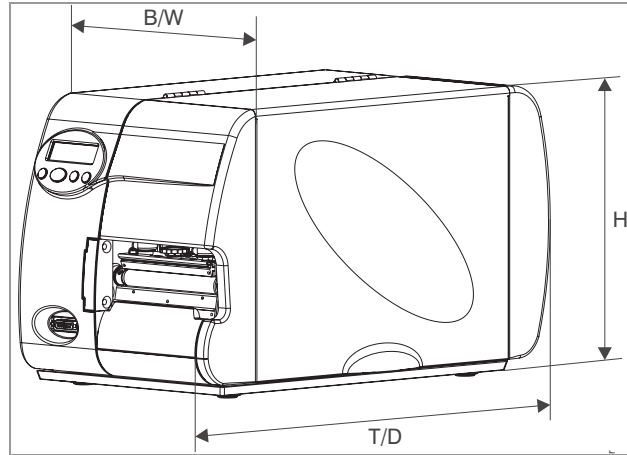

[1] Dimensions of the AP 5.6 and AP 5.4 (H=Height, W=Width, D=Depth).

Printer	Measures (H x W x D)
AP 5.4	272 x 260 x 462 mm
AP 5.6	272 x 337 x 462 mm

[Tab. 1] Measures

Weight

Printer	Weight
AP 5.4/5.6	14 kg
AP 5.4 basic / peripheral	14 kg
AP 5.4 dispenser / internal rewinder	16 kg

[Tab. 2] Printer weight

Performance Data

Print Technology Thermodirect and thermotransfer printing

Printer Head Type • “Flat Head” type (ceramic thin film flat head)
 • 8.0 dot/mm (203 dpi)
 • 11.8 dot/mm (300 dpi)

Printhead Characteristics

Printer	Resolution (Dot/mm)	Resolution (dpi)	Print-speed (mm/s)	Print-speed (Inch/s)	Max. printwidth (mm)
AP 5.4	8.0	203	50-200	2-8	104
	11.8	300	50-150	2-6	105.7
AP 5.6	8.0	203	50-200	2-8	168
	11.8	300	50-150	2-6	

[Tab. 3] Important printhead data.

Label sensor

Sensor type	Setting range (Size c)	Punch length (Size b)	Punch width (Size a)
Transmission sensor (Standard)	0–60 mm	0.8–14 mm	min. 4 mm
Reflex-sensor (optional)	6–66 mm	4 mm (recommended)	12 mm (recommended)

[Tab. 4] Required punch measures.

▣▣▣▣ The dark/light change at the reflex sensor is taken as the *label beginning* (= end of the reflex mark)

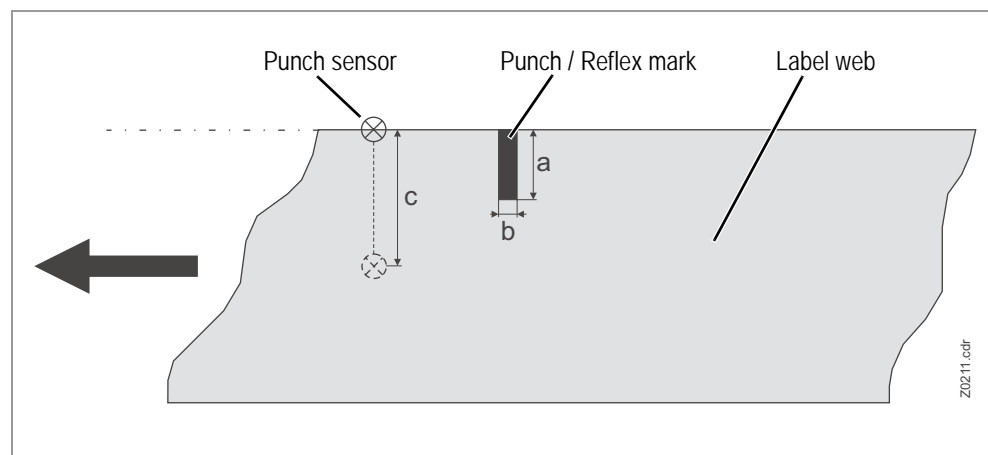

[2] Measures and setting range of the punch / reflex mark.

Max. print length	<p>The maximum print length depends on the following:</p> <ul style="list-style-type: none">• Printer type• Printer resolution• Firmware version• Parameter settings regarding memory allocation (e.g. SYSTEM PARAMETERS > Free store size)
Zero line	<p>Offset of the material zero line to the print zero line: 1 mm (what means that a stripe of 1 mm width at the inner label margin is unprintable)</p>
Fonts	<ul style="list-style-type: none">• 17 Fixsize fonts , including OCR-A and OCR-B• 3 scalable fonts (Speedo fonts)• Truetype fonts are supported• Optionally can Truetype, Speedo and Fixsize fonts be stored on SD-card
Modifying Fonts	<ul style="list-style-type: none">• Up to factor 8 scaling in x/y direction• Rotation by 0, 90, 180 and 270 degrees

Impression accuracy

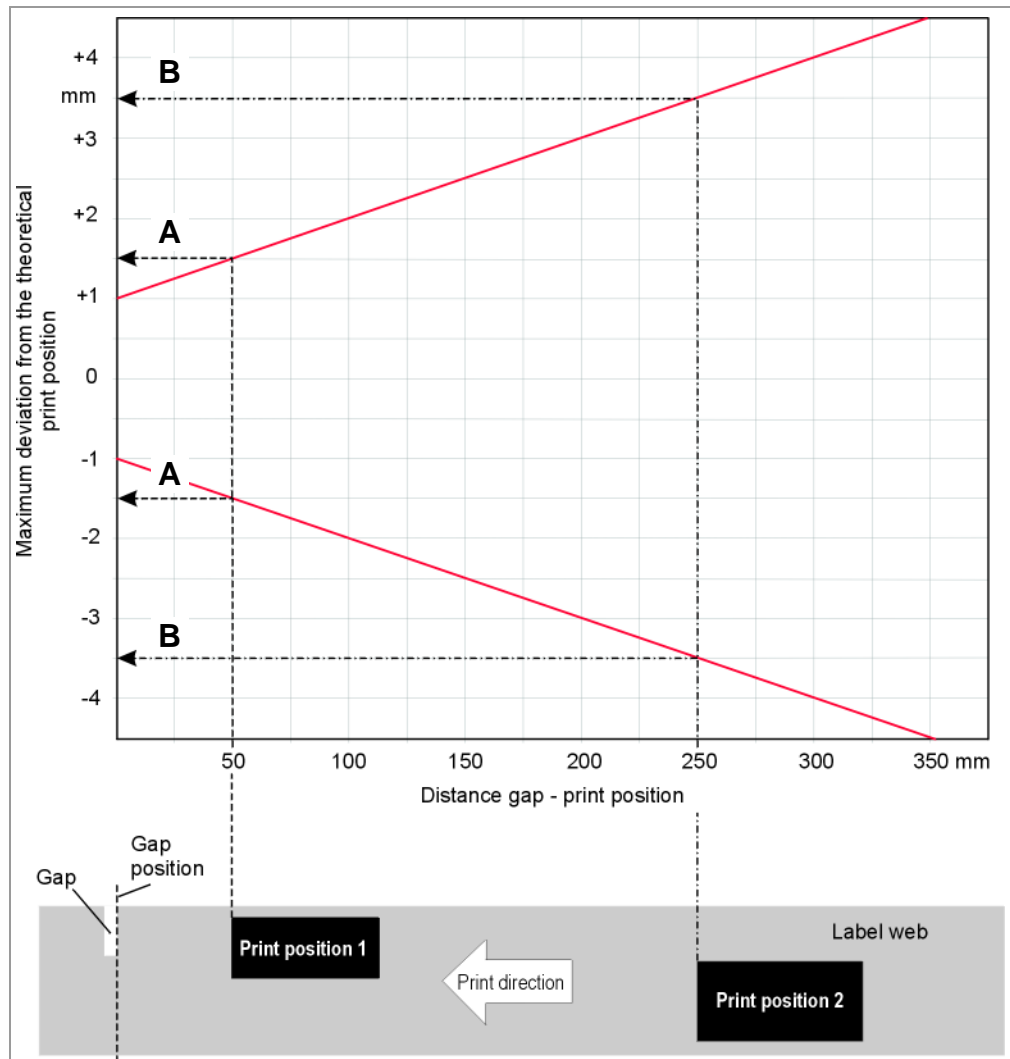

[3] The impression accuracy depends on the print position on the label: the longer the distance to the gap is, the lower is the impression accuracy. The maximum impression accuracy is at the gap position with +/- 1 mm.

Reading examples:

A: Print position 1 is located 50 mm behind the gap position. The maximum possible deflection from the theoretical print position is +/- 1.5 mm.

B: Print position 1 is located 250 mm behind the gap position. The maximum possible deflection from the theoretical print position is +/- 3.5 mm.

▣▣▣▣ Those values are empirical for typical applications with common label stock / foil combinations. Since the deflection of the print position strongly depends on the applied label stock / foil combination, it can turn out higher if unfavorable combinations are used.

Image formats

BMP, PCX, JPEG, TIFF, GIF, Easy Plug logos

AP 5.4 – AP 5.6

Bar codes

Codabar	Code 128 A, B, C
Code 128	Code 128 UPS
Code 128 pharmacy	ITF
Code 2/5 matrix	MSI
Code 2/5 interleaved	EAN 8
Code 2/5 5-line	EAN 13 add-on 2
Code 2/5 interleaved ratio 1:3	EAN 13 add-on 5
Code 2/5 matrix ratio 1:2,5	EAN 128
Code 2/5 matrix ratio 1:3	Postcode (guide and identity code)
Code 39	UPC A
Code 39 extended	UPC E
Code 39 ratio 2,5:1	Code 93
Code 39 ratio 3:1	

All bar codes scalable in 30 different width and in the height.

2-dimensional
bar codes

Data Matrix Code (code according to ECC200)
Maxi Code
PDF 417
Codablock F
Code 49
QR matrix code

GS1 Databar & CC
bar codes

Reduced Space Symbology (GS1 Databar) und Composite Component (CC) bar codes:

GS1 Databar-14	UPC-A + CC-A/CC-B
GS1 Databar-14 truncated	UPC-E + CC-A/CC-B
GS1 Databar-14 stacked	EAN 13 + CC-A/CC-B
GS1 Databar-14 stacked omnidirectional	EAN 8 + CC-A/CC-B
GS1 Databar limited	UCC/EAN 128 + CC-A/CC-B
GS1 Databar expanded	UCC/EAN 128 + CC-C

Printer emulation

Easy-Plug

AP 5.4 – AP 5.6

Label Stock

Material Types Thermodirect material, thermotransfer material, synthetic ribbons: PE, PP, PVC, PA in rolls or fan-folded.

Material Thickness

- *Self-adhesive labels*: 60 - 160 g/m²
- *Cardboard labels*:
 - AP 5.4: max. 240 g/m²
 - AP 5.6: max. 190 g/m²

Material Width

Printer type	Min. width	Max. width	Passage width
AP 5.4	15 mm	115 mm	120 mm
AP 5.4 dispenser	30 mm	105 mm	110 mm ^{a)}
AP 5.6	50 mm	180 mm	185 mm
AP 5.6 dispenser	50 mm	170 mm	175 mm ^{a)}

[Tab. 5] Overview material width.

a) The material passage width is limited by the dispensing sensor, which is mounted at the side. If a dispensing edge without a sensor is applied (foot switch operation), the passage width is as large as at the standard printer.

Label Length

Printer	Min. length	Max. length
AP 5.4	5 mm	max. print width ^{a)}
AP 5.4 dispenser	30 mm	200 mm
AP 5.4 dispenser ^{b)}	5 mm	200 mm
AP 5.6	5 mm	max. print width ^{a)}
AP 5.6 dispenser	30 mm	200 mm

[Tab. 6] Overview label length.

a) See [Max. print length](#) on page 6.

b) With optional label sensor for short labels.

Gap size

Gap size between the labels on the backing material:

- min.: 1.0 mm
- max.: Label length -15 mm

Label Roll

- *Winding Direction*: Labels facing inward or outward, internal rewinder: labels facing outwards

- *Roll diameter*:

Roll / Conditions	Roll Ø
Label roll for normal printing operation	max. 210 mm
Label roll for dispensing operation (with 100 mm core-Ø)	max. 190 mm
Take-up roll for winding/dispenser operation	max. 120 mm

[Tab. 7] Diameter of material and winding roll

- *Core diameter*: 38.1 mm (1.5"), 76.2 mm (3") oder 101.6 mm(4"); cores with 76.2 (3") or 101.6 mm (4") can be applied with the core adapter supplied with the printer.

AP 5.4 – AP 5.6

Thermotransfer Ribbon

Ribbon Roll

- *Winding Direction:* Colour-side rolled inwards or outwards
- *Roll measurements:*

External Ø	max. 80 mm
Core Ø	25 mm (1")
Width ^{a)}	AP 5.4: 25 -114 mm AP 5.6: 50-172 mm
Length	max. 500 m

a) Generally counts: The thermal transfer ribbon must overlap the label 2 mm on each side.
For labels wider than 168 mm counts: Foil width = 172 mm (max. ribbon width).

Connections, device data

Protection class	„I“
Mains Voltage	100-240 V (AC)
Mains Frequency	50-60 Hz
Power Consumption	<ul style="list-style-type: none"> • Max. 320 W • In standby mode depending on the equipment 30-40 W
Current Consumption	max. 3.2A

Interfaces

Interface	Details
RS-232	Baud: 1200-115200, 8- bit; suitable connection cord: 1:1 D-Sub 9 extension lead (connector-jack)
RS-422/485	On optional I/O board, D-Sub 15, Baud: 1200-115200, 8-bit
Ethernet	10/100 Base T with TCP/IP, LPD, RawIP printing, DHCP, HTTPD, FTPD, SNMP
USB (V1.1)	USB-A host port, USB-B device port, Transmission rate 12 Mbps
Signal interface	On optional I/O board, D-Sub 15

[Tab. 8] Data interfaces at AP 5.4/5.6

Detailed information on the interfaces can be found in the Service Manual, topic section [Service Electronics](#) , chapter “CPU boards”, “Interfaces”.

AP 5.4 – AP 5.6

Electronic Configuration

Feature	Details
CPU	32 bit RMI
RAM	32 MB SDRAM
ROM	4 MB Flash
Memory card	SD
Realtime-clock	Present
Control Panel	4 buttons; LCD graphics display with 128x32 pixels; typically used to display two text lines with 16 characters each

[Tab. 9] Electronic configuration of the AP 5.4/5.6.

Specifications only for AP 5.4/5.6 dispenser

- Speed, while the rewinding-Ø is calculated: 75 mm/s (3"/s)
- Speed, while the material is fed back: 75 mm/s (3"/s)
- Distance dispensing edge - print zero line: 25 mm
- Distance punch sensor - print zero line: 71 mm
- Max. admissible outer diameter of the rewound backing paper roll: 120 mm

Environmental Conditions

Operating Temperature	5 to 40°C
Storage Temp.	-4 to 60°C
Relative Humidity	30-85% (non-condensing)
Protection category	IP 21
Noise	70dB(A)

Test Marks, certificates

CE	<p>EU conformity: The devices fulfil the requirements of the following EU directives:</p> <ul style="list-style-type: none">• EMC Directive• Low Voltage Directive <p>For details refer to EC Declaration of conformity </p>
cTÜV _{US} -Mark	<p>TÜV test mark for USA and Canada:</p> <ul style="list-style-type: none">• USA: tested according to UL 60950-1• Canada: tested according to CAN/CSA-C22.2 No 60950-1
TÜV-Mark	<p>TÜV test mark for EU: tested according to EN 60950-1</p>
CB	<p>CB test certificate: tested according to IEC 60950-1</p>
FCC	<p>Declaration of conformity: FCC rules, part 15 class B devices</p>

Zubehör

Accessories

Fußschalter, Tastatur

Foot switch, Keyboard 2

Fußschalter, Tastatur / Foot switch, Keyboard



1



2



3

ID	Bezeichnung	Designation	Teilenummer / Part Number
1	Fußschalter	Foot switch	A4053 ¹ (AP4.4/5.4) 97685 ² (64-xx)
2	Tastatur	Keyboard	A8407 ³ (German layout) A8406 ⁴ (US layout)
3	Nummernblock (<i>Deutsches Layout</i>)	Number key block (<i>German layout</i>)	A4219 ⁵

1) Stecker wie abgebildet.
Plug as illustrated.

2) Stecker entspricht nicht der Abbildung.
Another plug as illustrated.

3) Adapter USB-zu-PS/2 wird mitgeliefert.

4) USB-to-PS/2 adapter is included.

5) Mit PS/2-Stecker - kann nur für AP 5.4 rot und 64-xx Gen. 2 verwendet werden.
With PS/2 connector - can only applied to AP 5.4 red and 64-xx Gen. 2.